

**Dry Magnetic Separation
of a Southwestern Wyoming Coal
Presented at the 18th International
Low-Rank Fuels Symposium
Billings, MT June 24-26, 2003**



EXPORTech Company, Inc.

Bldg. 242, Schreiber Industrial District, P.O. Box 588

New Kensington, PA 15068-0588



Tutorial on Magnetic Separation

Magnetism $F = m\sigma_m \nabla H$ (ml/t²)

$\sigma_m = \chi_m H$ Paramagnetism and diamagnetism

Magnetic Susceptibility of Mineral Matter – Eastern Steam Coals

Materials	Formulae	Magnetic Susceptibility Micro cc/g
Ferruginous Minerals	FeS ₂ , FeCO ₃ , FeSO ₄	+1 — +200
Non-Ferruginous	CaCO ₃ , Limestone, Clay, Shale, Sandstone	-0.5 — +20
	CaSO ₄ , Al ₂ (SO ₄) ₃ MgSO ₄	-0.4
Coal		-0.5

ParaMagÔ Separator

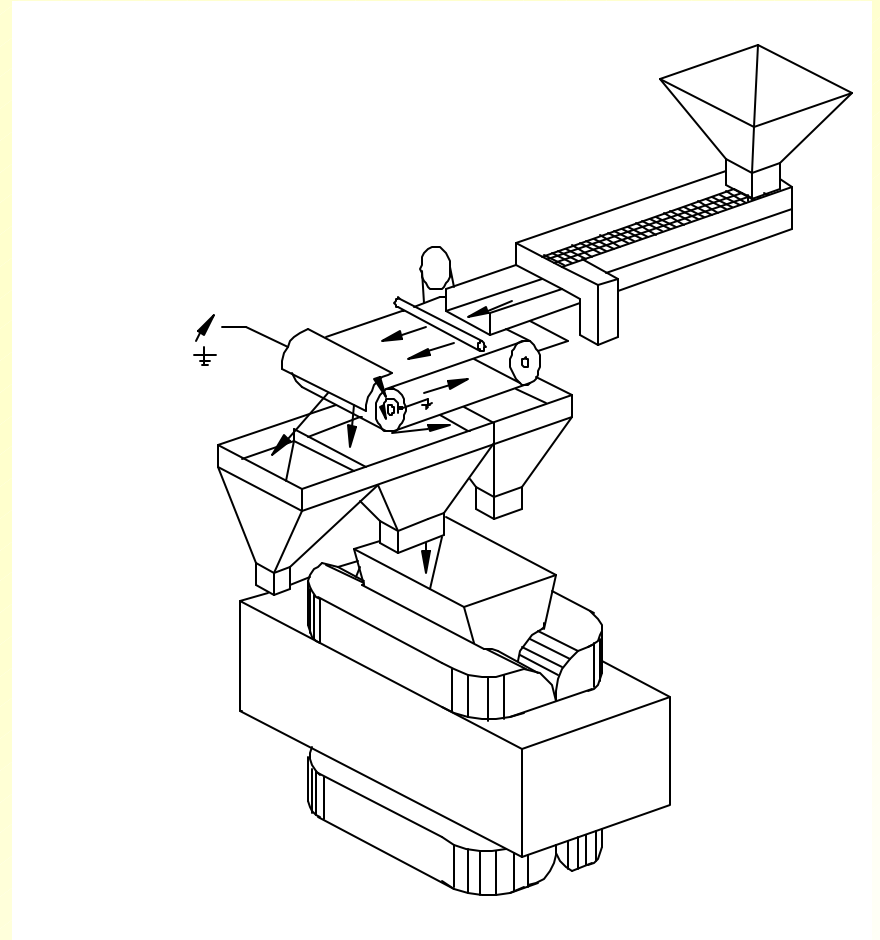

Lines of Magnetic Flux

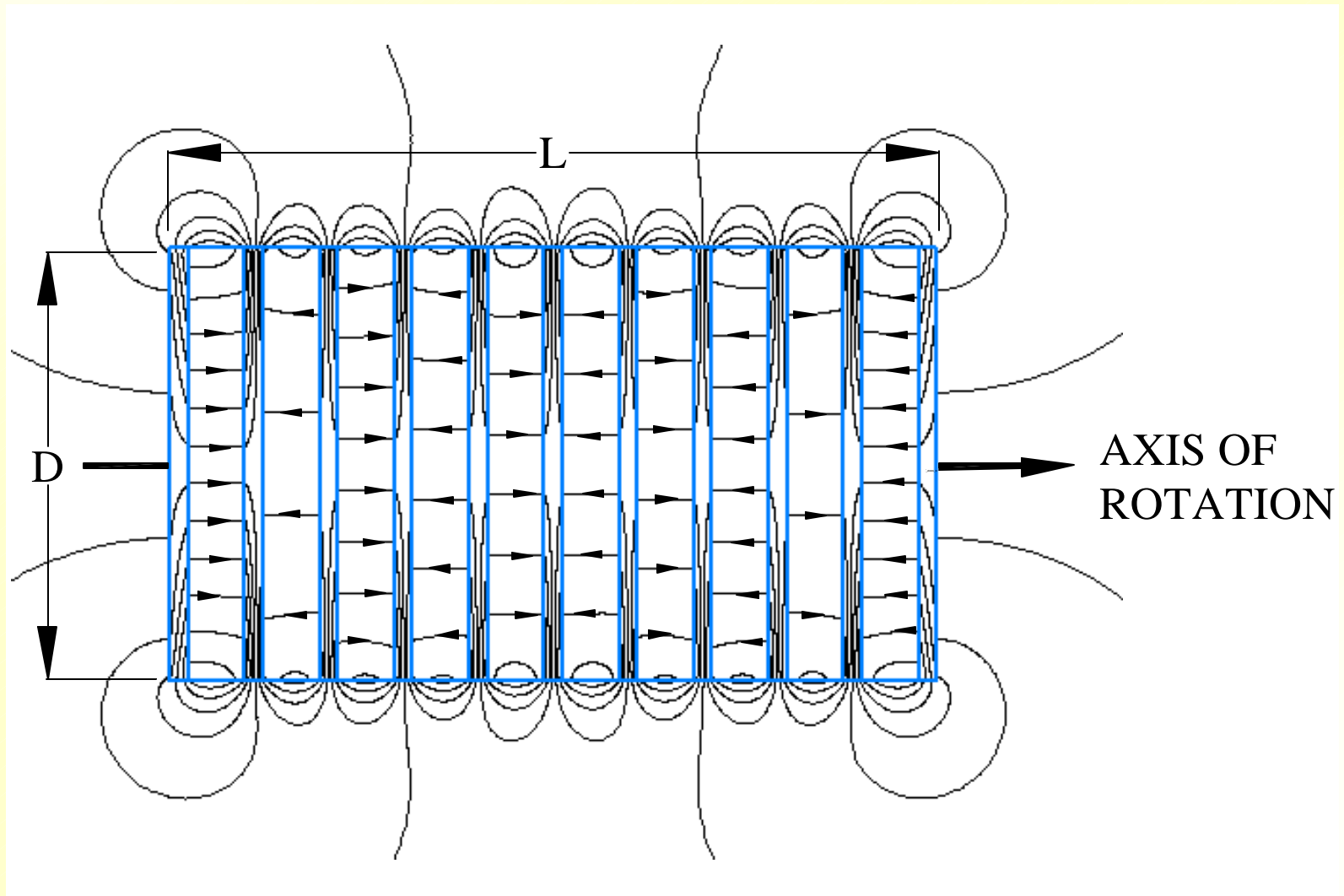

Separation Matrix

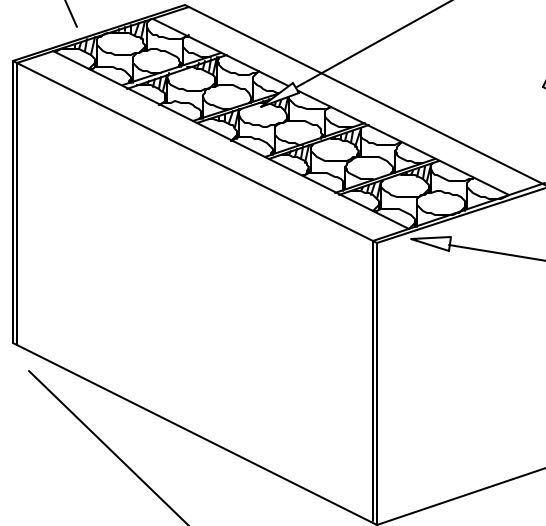

Poles

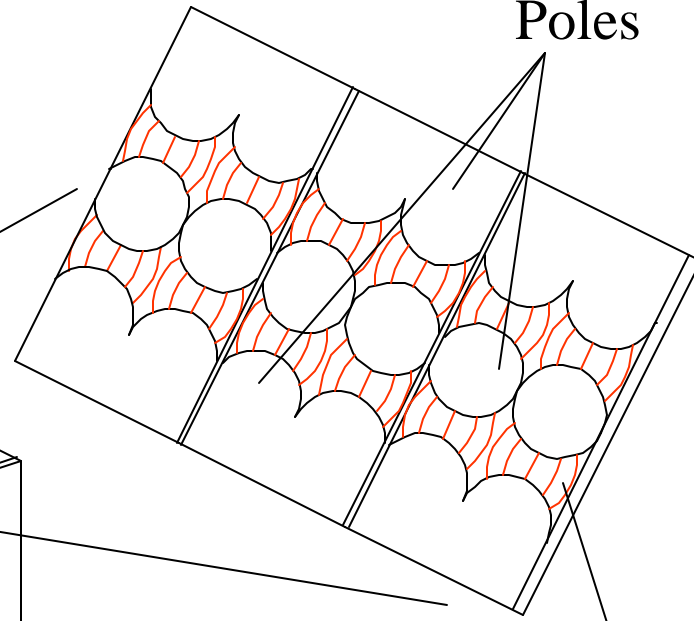

Field Lines

Electromagnet

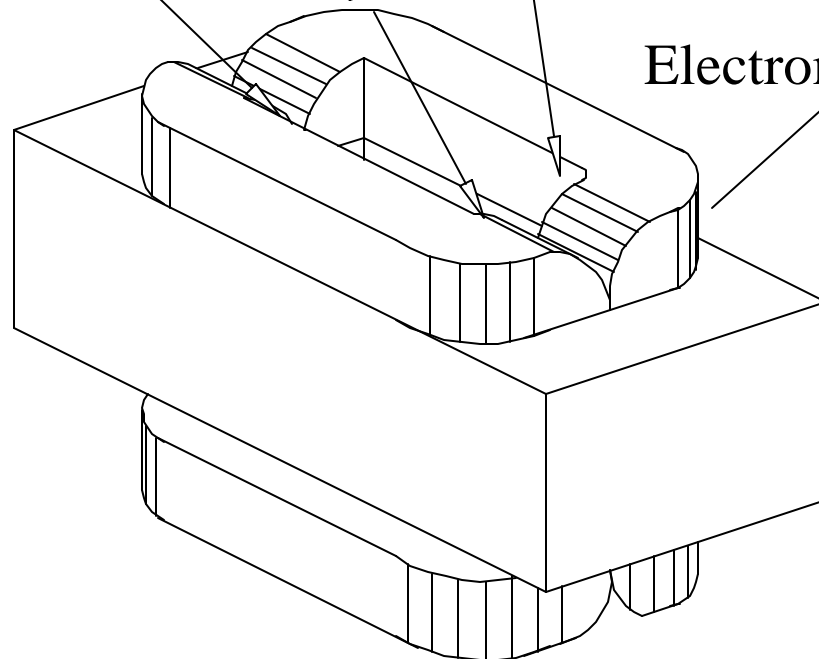

Kemmerer Coal

(dry basis)

Ash	6.22	wt.%
Sulfur		
Total	1.33	wt.%
Pyritic	0.62	wt.%
Sulfate	0.03	wt.%
Organic	0.68	wt.%
Heat Content	11,925	Btu/lb
SO ₂	2.23	LbSO ₂ /MBtu
Mercury	0.028	ppm
Arsenic	0.41	ppm
Magnetic Susceptibility	-0.13	micro cc/g

Grade & Recovery

Kemmerer Coal

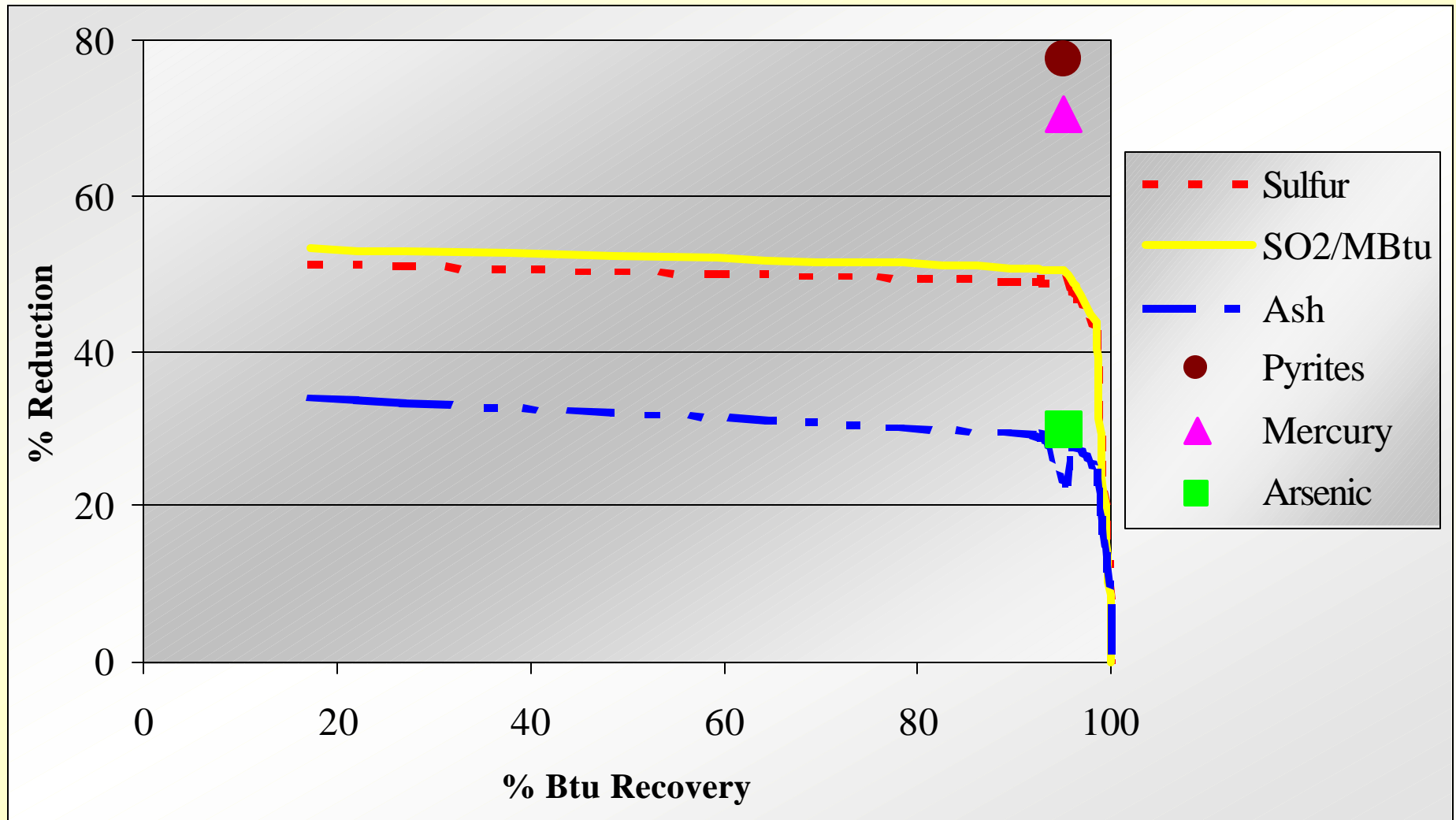

Raw and Cleaned Kemmerer Coal

95% Btu Recovery (dry basis)

	Feed Coal	Reject	Cleaned Coal	Reduction %	Recovery %
Weight Recovery, %	100	6.38	93.62		93.6
Heat Content	11,925	8,947	12,128		95.2
Carbon, wt. %	68.87	48.01	70.29		95.6
Ash, wt. %	6.22	30.37	4.57	26.48	
Sulfur, wt. %	1.33	10.41	0.71	46.57	
Pyritic Sulfur, wt. %	0.62	7.62	0.14	77.32	
LbSO ₂ /MBtu	2.23	23.27	1.17	47.5	
Mercury, ppm	0.028	0.318	0.008	70.45	
Arsenic, ppm	0.411	2.22	0.288	29.97	
Magnetic Susceptibility micro cc/g	-0.13	1.4	-0.23		

Kemmerer and Falkirk (dry basis)

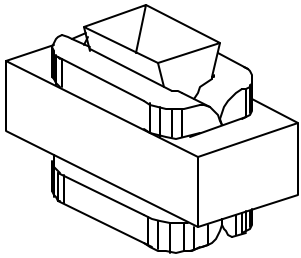

Kemmerer -16 Mesh
ParaMag Separator

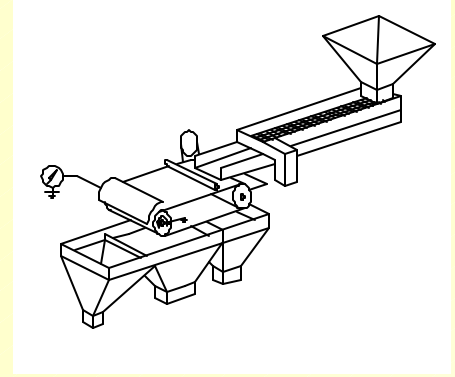

Falkirk -1/4 inch
Belt Separator

	Btu Recovery wt.%	Ash wt.%	Sulfur LbSO ₂ / MBtu	Magnetic Suscep. micro cc/gm	Btu Recovery wt.%	Ash wt.%	Sulfur LbSO ₂ / MBtu	Magnetic Suscep. Micro cc/gm
Feed	100.0	6.3	2.3	-0.13	100.0	35.6	3.5	11.1
Belt Product					90.9	26.8	3.2	2.3
Belt Reject					9.1	68.1	6.8	44.1
ParaMag Product	95	4.5	1.2	-0.23				
ParaMag Reject	5	30.4	23.3	1.4				

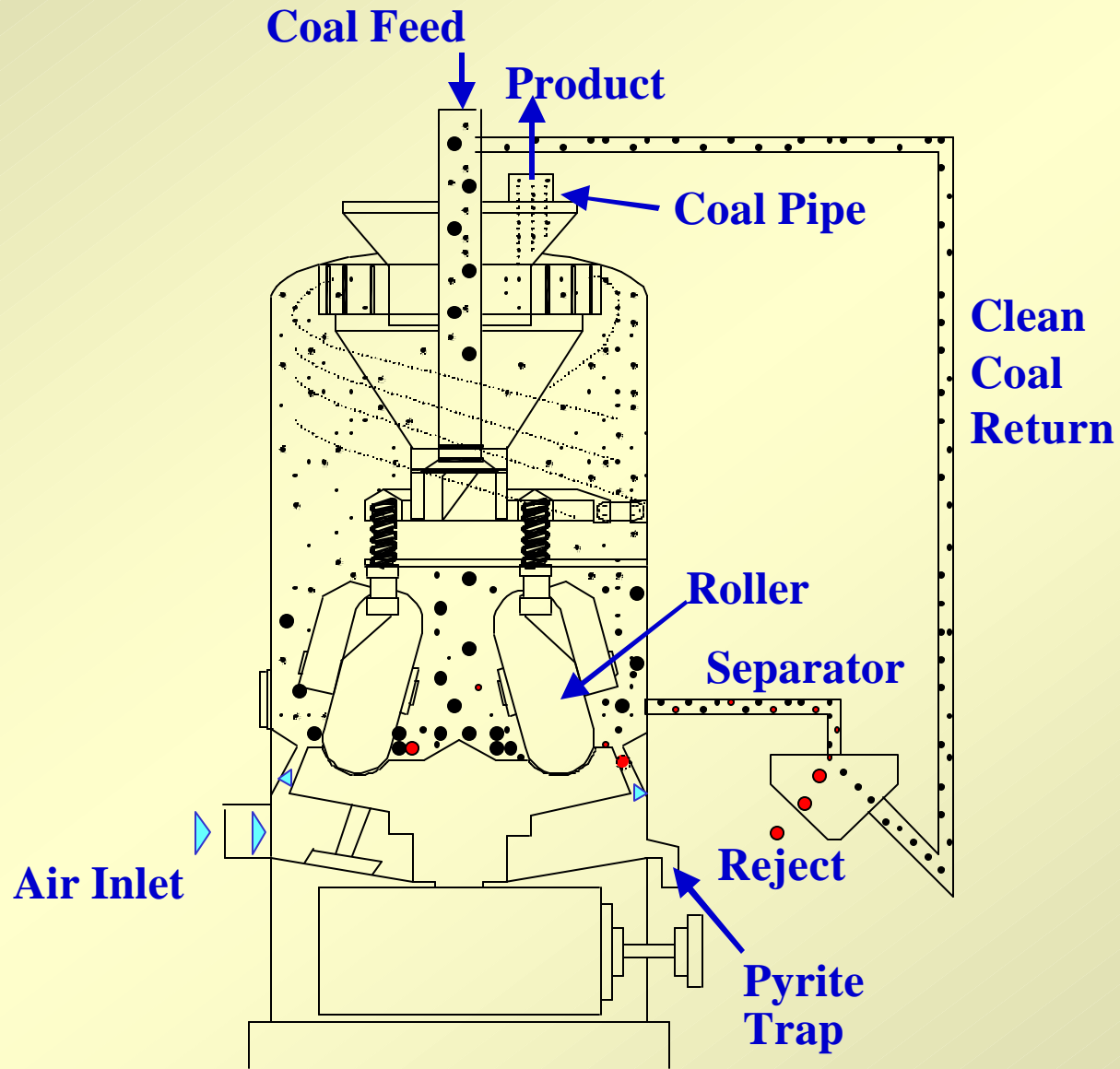

Beta Prototype MagMill™



MagMill[®] Technology

Feature

Advantages

Benefits

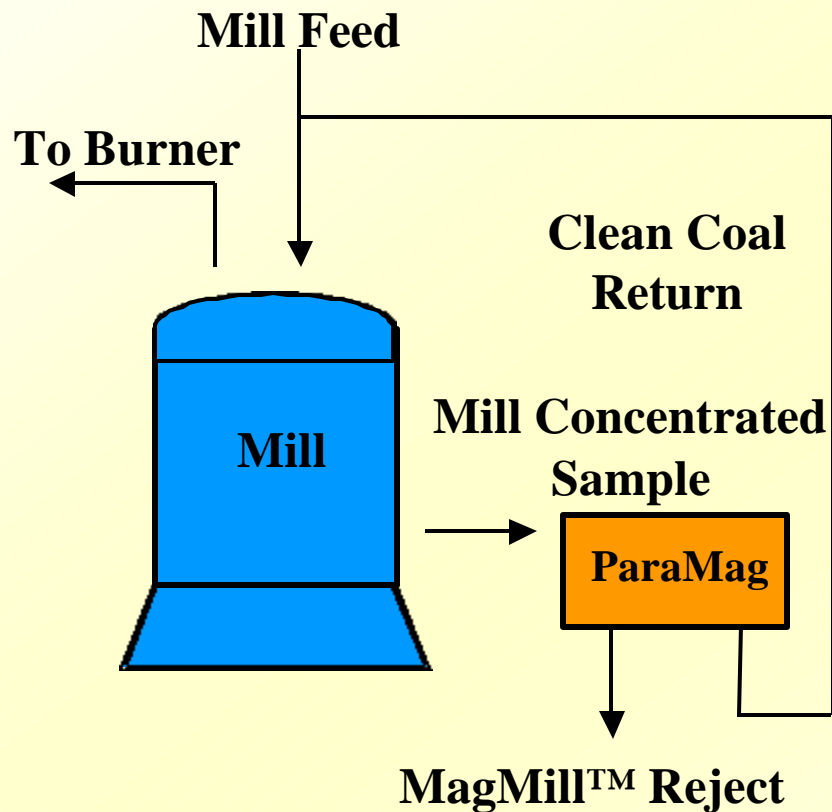

Better than
wet cleaning

Separate
abrasive minerals

No water

No additives

Scaleable

Mill

Reduced wear, power

Burners & Boilers

Slagging reduced
Less water wall wastage

Emissions

Sulfur Reduction
Mercury Reduction
Less arsenic to SCR

Fuels Procurement

Lowers overall costs

Summary

Dry Magnetic Processing

At The Mine

At the Generating
Station

Air Jig/Table — Coarse

MagMill — 8 M x 0

Belt Separator

and/or — Fine

ParaMag